

# JACO FITTINGS INSTALLATION INSTRUCTIONS

## INSTALLATION INSTRUCTIONS FOR JACO TUBE FITTINGS

1. Cut the tubing end squarely and remove the internal and external burrs.
2. Insert the tubing through the back of the nut all the way through the nut assembly to the tube stop in the fitting body (see illustration). If the tubing does not enter the nut easily, loosen the nut one turn and then insert the tubing all the way to the tube stop in the fitting body.
3. Turn the nut hand tight.
4. Wrench-tighten the nut 1-1/2 - 2 turns.
5. All nuts must be retightened when the system reaches projected operating temperature.

**NOTE:** Squeaking sound when tightening nut is normal. For pipe threaded connections, Teflon Tape\* must be used.

\*Dupont's Reg. T.M. Patent 1983

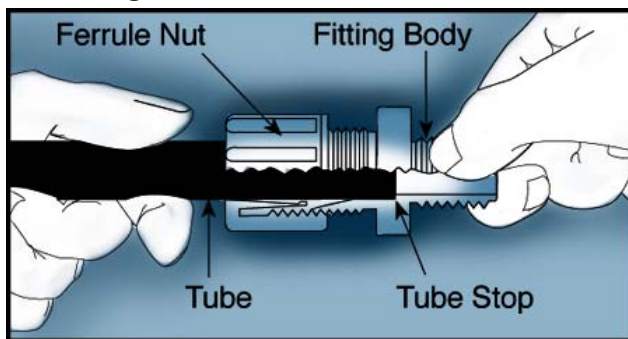

**NOTE:** It is not necessary to disassemble this fitting for application. Merely insert tubing to stop and tighten nut.

## ASSEMBLY INSTRUCTIONS FOR JACO NUTS

Please follow these diagrams in assembling nuts.

As shown below, insert gripper (B) into nut (A).

Push sleeve (C) into nut assembly.

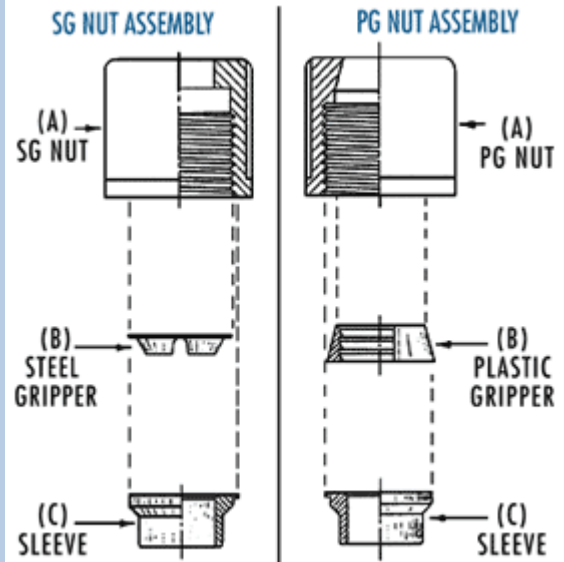

JACO Fittings Distributed by:



2450 Business Park Drive, Vista, CA 92081, USA

(760) 727-3711 • FAX: (760) 727-4427

Internet: [www.appliedmembranes.com](http://www.appliedmembranes.com)

E-mail: [sales@appliedmembranes.com](mailto:sales@appliedmembranes.com)

